



ELLISON - AUXIER  
ARCHITECTS  
924 Francis Street  
St. Joseph, MO 64501  
v: (816) 233-8003, f: (816) 233-7793  
ellison-auxier.com

## **Addendum No. 1**

Date: April 5, 2021

Project: Roof Repairs, Murphy Hall & Hearnes Hall, Missouri Western State University  
**FB 21-046**

### **All Prospective Bidders:**

**All bidders furnishing necessary materials and/or labor, this addendum is hereby part of the Contract Documents as though it were originally therein. Refer to Proposal Form for acknowledgement of Addenda.**

### **Addendum Items:**

1. Completion date shall be June 18, 2021. Please use the attached Bid Form.
2. Bidders must provide a W-9 with their bid.
3. Successful bidder shall list Missouri Western state university as additional insured.
4. See the attached Pre-Bid attendance sheets.
5. Access and set up areas will be determined with successful bidder. Any rutting in grass areas will need to be re graded by contractor at the completion of the project.
6. All lightning protection shall be removed and replaced. Recertification is not required.
7. Accidental puncture and hail damage coverage is not required.
8. Remove the abandoned conduit and wire on Murphy roof.
9. The two canopy sections on Murphy are to be included in the work. See attached drawing.



ELLISON - AUXIER  
ARCHITECTS  
924 Francis Street  
St. Joseph, MO 64501  
v: (816) 233-8003, f: (816) 233-7793  
ellison-auxier.com

10. There is no work required on the penthouse roofs at Hearnese.
11. The existing north RTU will be removed from Hearnese by owner. All unused equipment curbs shall be removed by contractor.
12. The three satellite dishes on Hearnese will be removed by owner. All equipment curbs shall be removed by contractor.
13. The RTU's on the east half of Hearnese do not need to be re flashed.

**End of Addendum**

**SECTION 00 4100**

**BID FORM**

**THE PROJECT AND THE PARTIES**

**1.01 TO:**

- A. Owner  
Missouri Western State University  
4525 Downs Drive  
St. Joseph, MO

**1.02 FOR:**

- A. Project: Roof Repairs to Murphy Hall and Hearnes Hall FB21-046

**1.03 DATE: \_\_\_\_\_ (BIDDER TO ENTER DATE)**

**1.04 SUBMITTED BY: (BIDDER TO ENTER NAME AND ADDRESS)**

- A. Bidder's Full Name \_\_\_\_\_
  - 1. Address \_\_\_\_\_
  - 2. City, State, Zip \_\_\_\_\_

**1.05 OFFER**

- A. Having examined the Place of The Work and all matters referred to in the Instructions to Bidders and the Bid Documents prepared by Ellison - Auxier Architects, Inc. for the above mentioned project, we, the undersigned, hereby offer to enter into a Contract to perform the Work for the Sum of:

- B. Base Bid #1 Murphy Hall  
\_\_\_\_\_ dollars  
(\$ \_\_\_\_\_), in lawful money of the United States of America.

- C. Base Bid #2 Hearnes Hall  
\_\_\_\_\_ dollars  
(\$ \_\_\_\_\_), in lawful money of the United States of America.

- D. Combined Bid Murphy and Hearnes Halls  
\_\_\_\_\_ dollars  
(\$ \_\_\_\_\_), in lawful money of the United States of America.

- E. We have included the required security deposit as required by the Instruction to Bidders.
- F. We have included the required performance assurance bonds in the Bid Amount as required by the Instructions to Bidders.
  - 1. The cost of the required performance assurance bonds is \_\_\_\_\_ dollars  
(\$ \_\_\_\_\_), in lawful money of the United States of America.

**1.06 ACCEPTANCE**

- A. This offer shall be open to acceptance and is irrevocable for thirty days from the bid closing date.
- B. If this bid is accepted by Owner within the time period stated above, we will:
  - 1. Execute the Agreement within seven days of receipt of Notice of Award.
  - 2. Furnish the required bonds within seven days of receipt of Notice of Award.
  - 3. Commence work within seven days after written Notice to Proceed of this bid.
- C. If this bid is accepted within the time stated, and we fail to commence the Work or we fail to provide the required Bond(s), the security deposit shall be forfeited as damages to Owner by reason of our failure, limited in amount to the lesser of the face value of the security deposit or the difference between this bid and the bid upon which a Contract is signed.

- D. In the event our bid is not accepted within the time stated above, the required security deposit shall be returned to the undersigned, in accordance with the provisions of the Instructions to Bidders; unless a mutually satisfactory arrangement is made for its retention and validity for an extended period of time.

**1.07 CONTRACT TIME**

- A. If this Bid is accepted, we will:
- B. Complete the Work by the 18th day of June, 2021.

**1.08 CHANGES TO THE WORK**

- A. When Architect establishes that the method of valuation for Changes in the Work will be net cost plus a percentage fee in accordance with General Conditions, our percentage fee will be:
  - 1. 5 percent overhead and profit on the net cost of our own Work;
  - 2. 5 percent on the cost of work done by any Subcontractor.
- B. On work deleted from the Contract, our credit to Owner shall be Architect-approved net cost plus 100 % of the overhead and profit percentage noted above.

**1.09 ADDENDA**

- A. The following Addenda have been received. The modifications to the Bid Documents noted below have been considered and all costs are included in the Bid Sum.
  - 1. Addendum # \_\_\_\_\_ Dated \_\_\_\_\_.
  - 2. Addendum # \_\_\_\_\_ Dated \_\_\_\_\_.

**1.10 BID FORM SIGNATURE(S)**

- A. The Corporate Seal of
- B. \_\_\_\_\_
- C. (Bidder - print the full name of your firm)
- D. was hereunto affixed in the presence of:
- E. \_\_\_\_\_
- F. (Authorized signing officer, Title)
- G. (Seal)
- H. \_\_\_\_\_
- I. (Authorized signing officer, Title)

**1.11 IF THE BID IS A JOINT VENTURE OR PARTNERSHIP, ADD ADDITIONAL FORMS OF EXECUTION FOR EACH MEMBER OF THE JOINT VENTURE IN THE APPROPRIATE FORM OR FORMS AS ABOVE.**

**END OF SECTION**

HEARNES AND MURPHY ROOF REPAIR

NAME AND ADDRESS	COMPANY	PHONE	E-MAIL ADDRESS
JEFF ELLISON	Ellison-Auriv. Arch.	6233-8003	jeff@ellison-auriv.com
Dennis Harris	Hammill	516-596-0825	dennis@hausman.com
Kelly Owens	Seaman & Schuster	816-261-7206	kowens@seaman-schuster.com
Bill Adams	Roberts Roofing	816-244-8596	robertsroofing@adl.com
Cory Stewart	MUSC	271-42118	
Wally Starn	MUSC	4465	starn@...

042062

HEARNES AND MURPHY ROOF REPAIR

NAME AND ADDRESS	COMPANY	PHONE	E-MAIL ADDRESS
Hans Stutz 4141 Fairbanks Ave KC, KS 66106	Delta Innovative Services Inc.	(913) 371 7100	hstutz@delta services.com
Robert McQuinn #1642 2412 S. Bell Hwy St. Joseph, MO 64503	A1 Roofing Renovations Repair	816-259-5112	Robert@RoofsbyA1.com

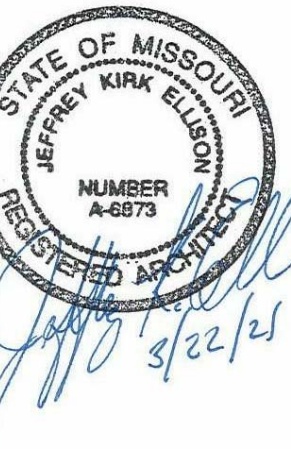

NO.	ISSUE DESCRIPTION	DATE

NO.	REVISION DESCRIPTION	DATE
ADDENDUM #1	4-5-21	

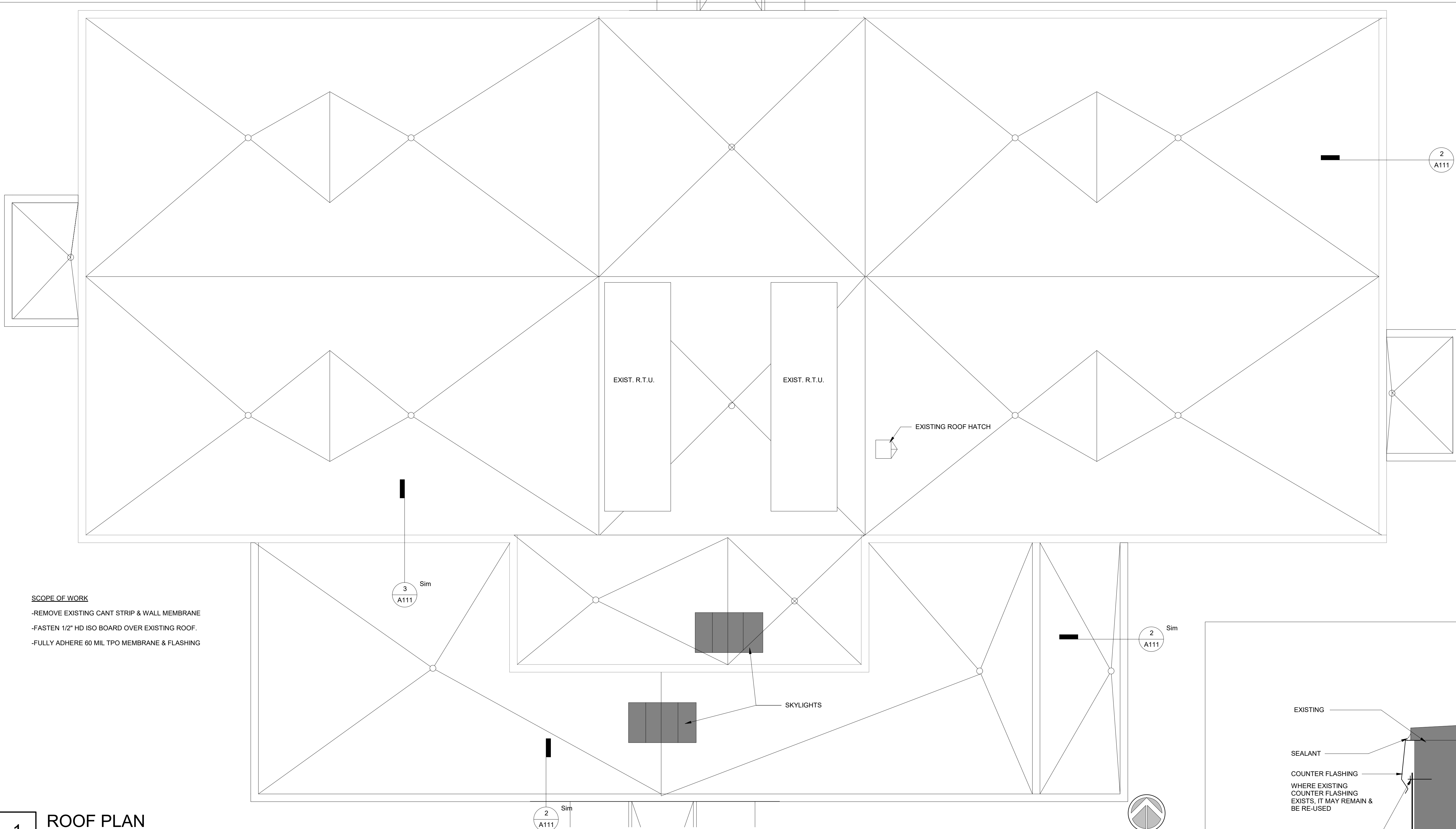

**SCOPE OF WORK**  
-REMOVE EXISTING CANT STRIP & WALL MEMBRANE  
-FASTEN 1/2" HD ISO BOARD OVER EXISTING ROOF.  
-FULLY ADHERE 60 MIL TPO MEMBRANE & FLASHING

**1 ROOF PLAN**  
SCALE: 1/8" = 1'-0"

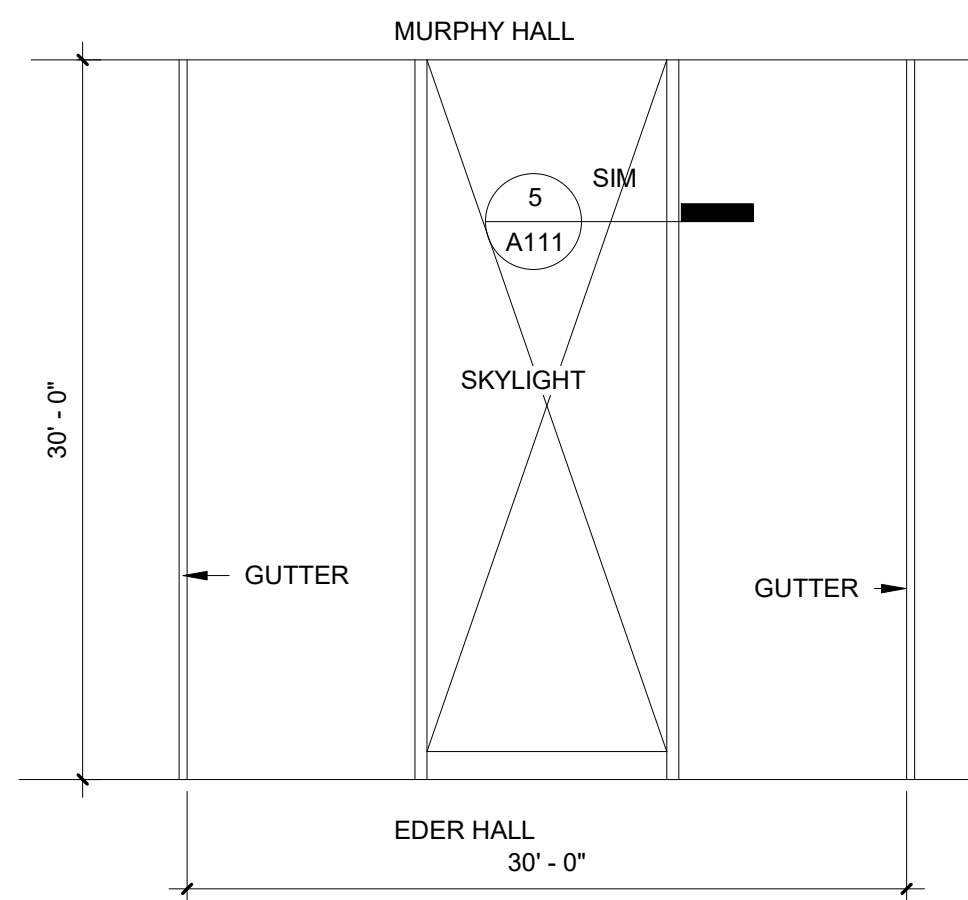

**4 CANOPY ROOF PLANS**  
SCALE: 1/8" = 1'-0"

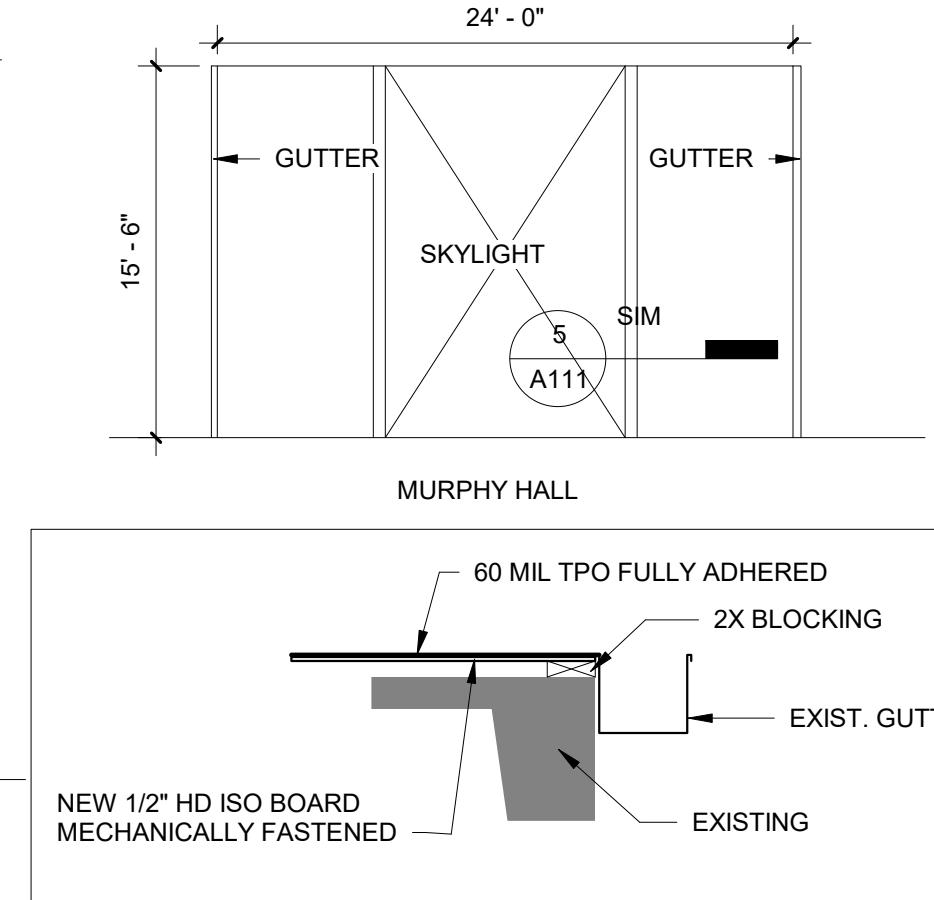

**6 GUTTER DETAIL**  
SCALE: 1/2" = 1'-0"

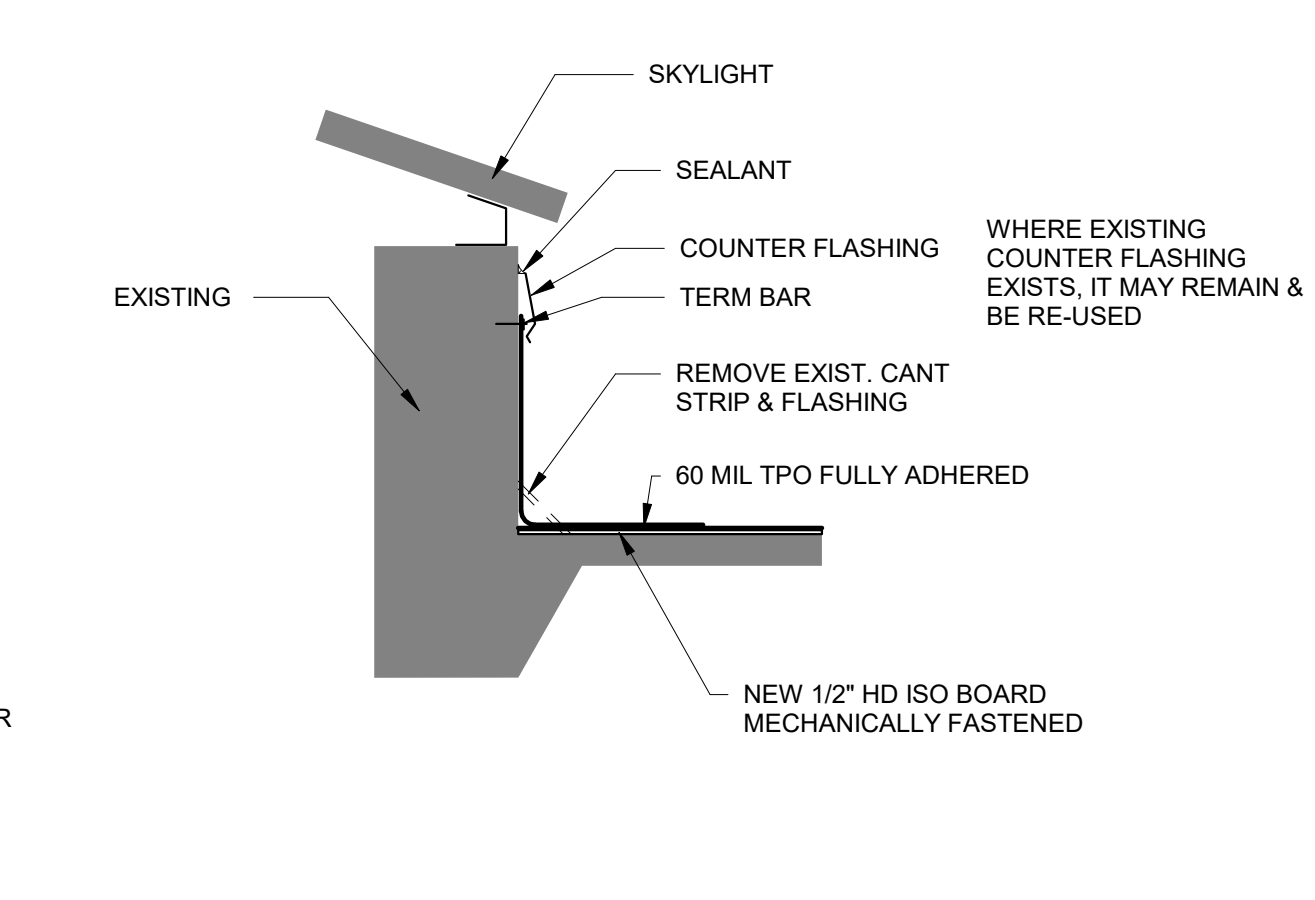

**5 SKYLIGHT FLASHING DETAIL**  
SCALE: 1/2" = 1'-0"

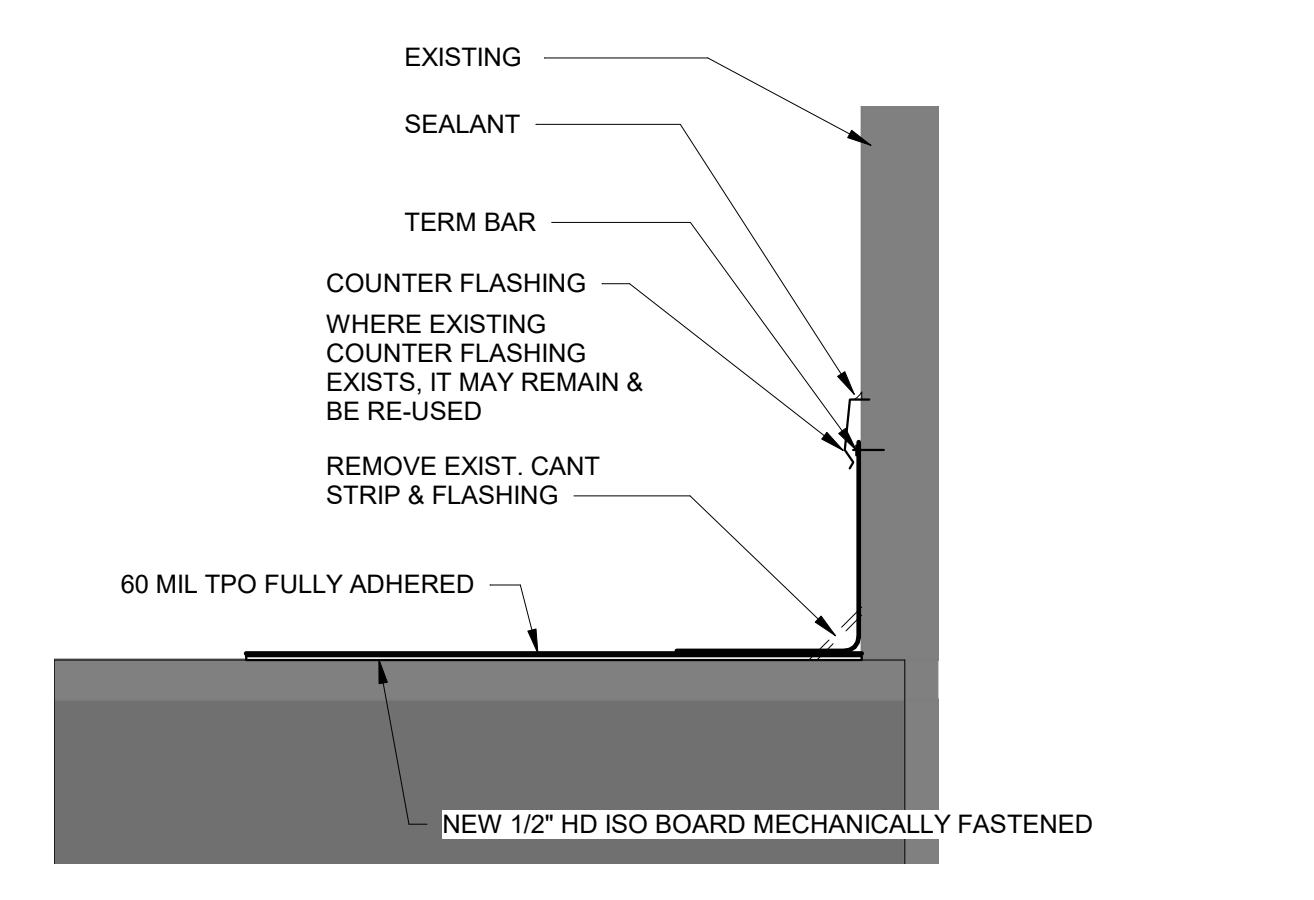

**3 FLASHING DETAIL 1**  
SCALE: 1/2" = 1'-0"

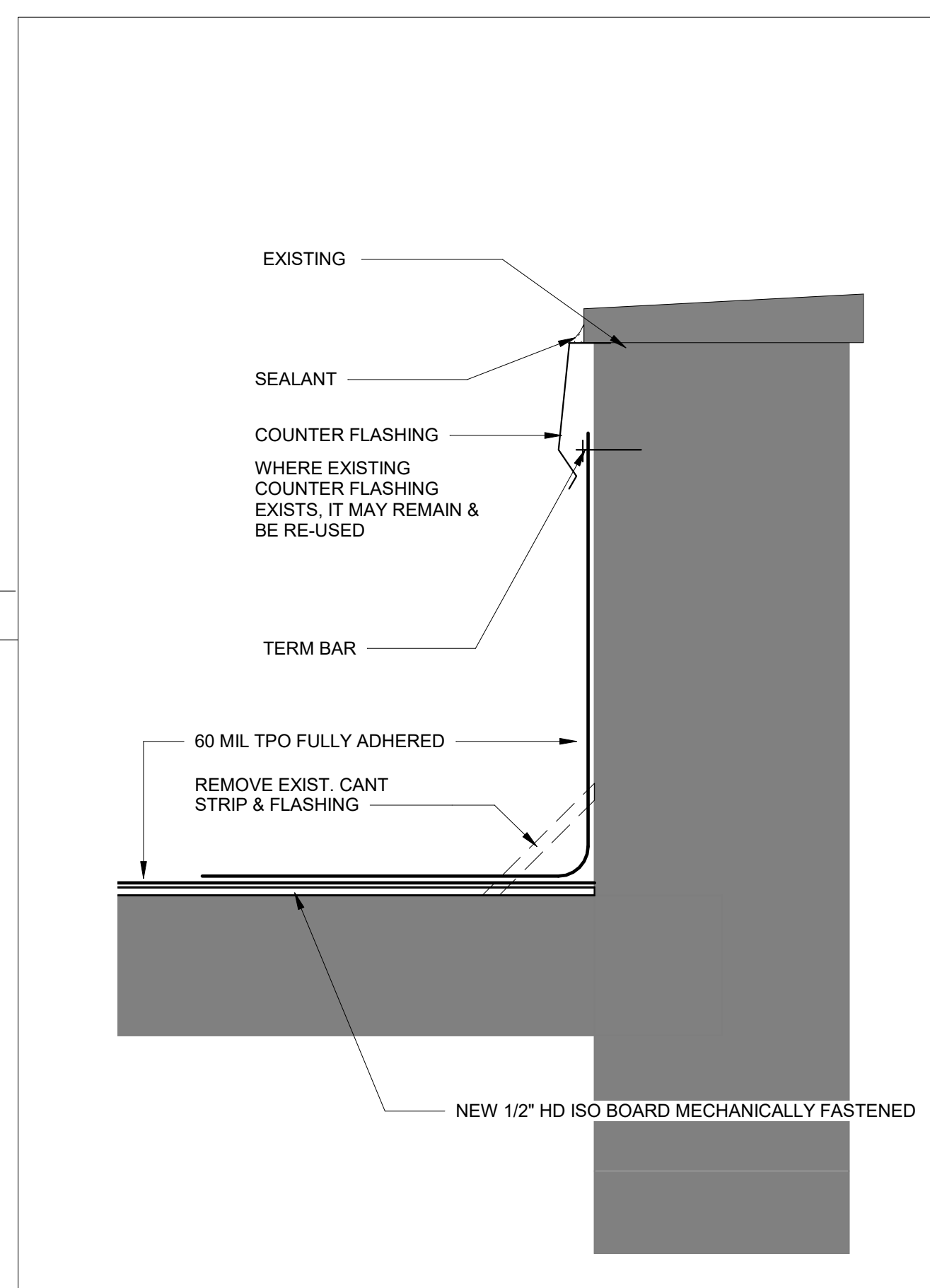

**2 FLASHING DETAIL 2**  
SCALE: 1 1/2" = 1'-0"